

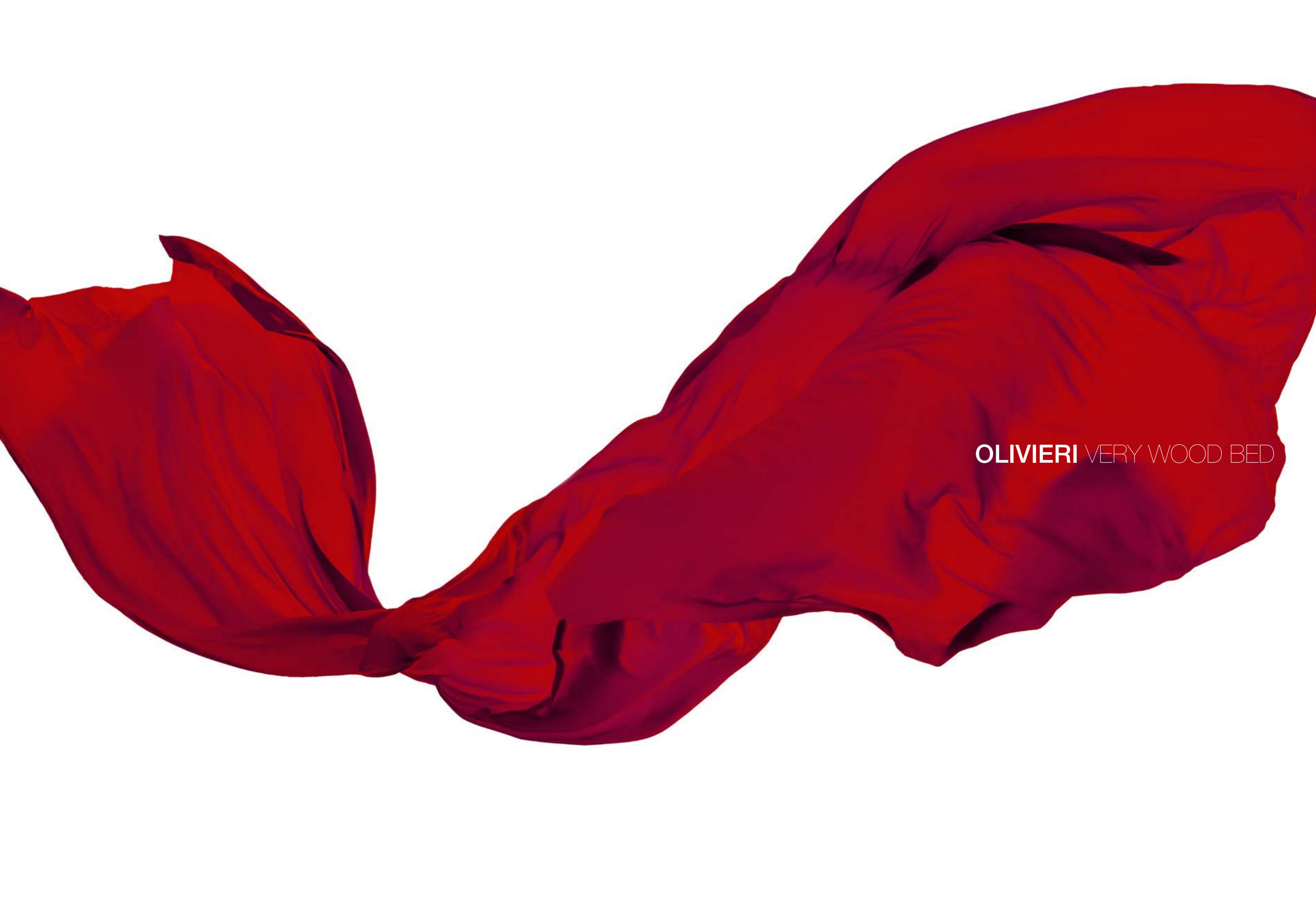

OLIVIERI

OLIVIERI VERY WOOD BED

OLIVIERI VERY WOOD BED



OLIVIERI VERY WOOD BED



STORIE AZIENDALI IL FASHION ENTRA IN FALEGNAMERIA

A completamento del progetto Very Wood, presentiamo la nuova collezione gruppi letto Very Wood Bed. Ancora una volta vogliamo dimostrare la nostra esperienza, leadership e know-how nel mondo del legno, presentando tutte collezioni di gruppi letto in legno, ognuna della quali presenta differenti valori e lavorazioni artigianali. Per la prima volta nei nostri 88 anni di storia, il concetto di “moda” entra in falegnameria. Una nuovissima e vasta scelta di tessuti romantici di un'epoca quasi fuori tempo, fino ai nuovi rivestimenti in pelle di altissima qualità si intrecciano in un caldo abbraccio con il nostro mondo del legno. Una collezione che non ha bisogno di tante parole: le immagini si esprimono da sole.

di **Veronica Semprini**

COMPANY STORIES FASHION INSIDE WOODWORKING

To fulfill the Very Wood project, we present the new collection Very Wood Bed. Once again we want to show our experience, leadership and know-how, launching the new wooden bed collections, each one with different woodworking details and values. For the very first time, in our 88 years old history, the “fashion” concept come inside our factory. A newest and wide range of romantic fabrics coming from a timeless age and high quality updated leathers mix together in a warm embrace with the Wood world. A wordless collection: images express by themselves.

by **Veronica Semprini**

ANDR

ANDREA

Originale ed accogliente, la collezione Andrea associa un'idea di bellezza tradizionale a dettagli di memoria.

La testata imbottita del letto fortemente caratterizzante, e la struttura in legno molto alta, rappresentano le linee guida di questa collezione.

Andrea is trendy and inspiring, Andrea collection expresses either beauty and memory for the past at the same time.

The strong character of the upholstered headboard and the high bed frame represent the guidelines of this collection.





JOHN DERIAN



Letto Andrea in rovere Carbon e cuscino in Eco-Nabuk stropicciato Tortora. Comodino Andrea con struttura e maniglia in rovere Carbon e cassetti in Lino opaco. Settimanali Andrea con struttura e maniglia in rovere Carbon e cassetti in oleo-malta "Wave" Lino opaco. Interno cassetti in Tortora effetto pelle. Panchetta in rovere Carbon e cuscino in Eco-Nabuk stropicciato Tortora.

Carbon oak Andrea bed with wrinkled effect Tortora Eco-Nabuk cushion. Andrea nightstand with structure and handle in Carbon oak and mat Lino drawers. Andrea high units with structure and handle in Carbon oak and Lino mat oleo-malta "wave" effect. Tortora leather effect drawer internal. Bench in Carbon oak and wrinkled effect Tortora Eco-Nabuk cushion.







Nella pagina precedente armadio Glass battente con ante in vetro Tortora lucido e colonne "a vetrina" in vetro trasparente naturale. Nel dettaglio a sinistra il tavolino vetro Andrea con struttura in rovere Carbon; la specchiera Andrea e la poltroncina Softly in Eco-Nabuk stropicciato Tortora.

In the previous page, Glass wardrobe with Tortora high gloss glass and window module in natural clear glass. On the left hand-side detail, glass table top Andrea with Carbon oak structure; Andrea mirror and Softly small armchair in wrinkled effect Tortora Eco-Nabuk.





Letto Andrea in rovere Visone e cuscino in Velluto Decoro cardinale. Comodino Andrea con struttura e maniglia in rovere Visone e cassetti in oleo-malta "Pizzo" Lino opaco. Comò Andrea con struttura e maniglia in rovere Carbon e cassetti in Lino opaco. Panchetta in rovere Visone e cuscino stretto in velluto decoro cardinale. Nella pagina successiva l'armadio antone Basic a 3 ante da 144 centimetri, con pannelli centrali in oleo-malta "Pizzo" Lino opaco.

Andrea bed in Visone oak and Decoro Velvet cardinale. Andrea nightstand with structure and handle in Visone oak and mat Lino oleo-malta "Pizzo" drawers. Andrea chest with structure and handle in Carbon oak and mat Lino drawers. Bench in Visone oak and small cushion Decoro Velvet cardinale. In the next page, antone Basic wardrobe with 3 doors of 144 centimeters, with central panels in mat Lino oleo-malta "Pizzo".









Letto Andrea in rovere Bianco a poro aperto e cuscino in tessuto Lalique Bianco. Comodino Ray in laccato Bianco lucido. Nei dettagli si apprezza la speciale lavorazione del piede e l'imbottitura della testata.

Andrea bed in White open pore oak and Lalique Bianco cushion. Ray nightstand in high gloss White. Details of the foot special woodworking and headboard upholstery.



KAL

KAL

Il calore e la morbidezza dei cuscini, uniti alla ricchezza del giroletto in legno massello, rendono Kal un letto all'insegna di un nuovo concetto di eleganza domestica, quello di vivere appieno, in completa libertà e senza rinunce, gli spazi della propria vita e del proprio quotidiano.

The warmth and softness of cushions, mixed with richness of massive wood bedframe make Kal a new home luxury concept of bed elegance, in complete freedom and without renouncing each space of your daylife.







Letto Kal in rovere Carbon e coppia di cuscini in Pelle Vintage Tortora abbinata alla scrivania Vanity. Nei dettagli la particolare lavorazione della struttura in legno massello arrotondato e delle cuciture "punto cavallo" sul retro della testata disponibili in 8 colori. Scrivania "make up" Vanity in laccato Tortora opaco con cornice in rovere Carbon. Poltroncina Softly in Eco-Nabuk stropicciato Tortora. Nella pagina successiva armadio Antone Gap A1, con pannelli centrali in rovere Carbon e pannelli superiori ed inferiori in laccato Tortora opaco.

Kal bed in Carbon oak and set of cushions in Leather Vintage Tortora, combined with Vanity desk. In details, special structure woodworking in rounded massive wood and "blanket stitch" in the back of the headboard, available in eight colors. "Make up" Vanity desk in Tortora mat with basement frame in Carbon oak. Small armchair Softly in wrinkled effect Tortora eco-nabuk. In the next page Gap A1 Antone wardrobe, with central panels in Carbon oak and upper/lower panels in Tortora mat.









Letto Kal in rovere Visone vissuto con cuscini in Cotone Juta abbinato al gruppo letto Ginevra in rovere Visone vissuto con maniglia nera. Nei dettagli la lavorazione del piedino del letto Kal, il gruppo letto Ginevra e le poltrone Softly in tessuto Lalique Seta abbinate al tavolino Andrea in rovere Visone.

Kal bed in aged Visone oak with Juta Cotton cushions combined with Ginevra night stand in aged Visone oak with black handle. Details show Kal bed foot woodworking, Ginevra collection and Softly armchairs in Seta Lalique matching Visone oak Andrea low table.



MARTIN

MARTIN

Caratterizzato dalle forme morbide del legno,
Martin concilia tradizione ed eleganza con un look
contemporaneo.

*Featured by the soft shapes of the wood, Martin combines
tradition and elegance with a contemporary look.*







Letto Martin laccato Lino opaco con testata del letto nella speciale finitura oleomalta "Pizzo" Lino. Nei dettagli la testata del letto, la pediera, e i comodini Martin con i frontali nella medesima finitura di "oleo-malta".

Lino mat Martin bed with special "Pizzo" Lino oleo-malta finishing. Details of bed headboard, footboard, and Martin nightstand with fronts in the same "oleo-malta" finishing.







Letto Martin-soft in rovere Cenere poro aperto con cuscini in Eco-Nabuk stropicciato Blu Notte abbinato al gruppo letto Ray in laccato lucido Bianco. Nei dettagli si apprezza la finitura stropicciata del tessuto; il comodino e i settimanali Ray.

Martin-soft bed in Cenere open pore oak with cushions in Blu Notte wrinkled effect Eco-nabuk combined with Ray collection in high gloss White. The details show the fabric creasing; Ray nightstand and chests.







Letto Martin-soft in rovere Visone vissuto con cuscini in Eco-Pelle Fango abbinato al proprio gruppo letto con struttura e maniglia gola in rovere Visone, e frontali in laccato opaco Lino. Nei dettagli l'effetto "vintage" dell'eco-pelle, il dettaglio della pediera in rovere Visone, e il comò Martin. Nella pagina successiva armadio Antone Decor "Shanghai" con maniglia Gap A1 in laccato Tortora opaco.

Martin-soft bed in Visone aged oak with cushions in Fango Eco-Leather matching its collection with Visone built-in handle and structure, and drawers in Lino mat. Particular of the eco-leather "vintage" effect, the detail of footboard in Visone oak and Martin chest. Next page, Antone Decor "Shanghai" wardrobe with Gap A1 handle in Tortora mat.





LEONARDO

LEONARDO

Il gioco delle inclinazioni unito al calore del legno e a dettagli di forte personalità, rendono questa collezione affascinante ed adatta a chi ama circondarsi di oggetti unici.

The combination of bends linked with warmth of the wood and details of strong personality, make this collection attractive and suitable for those who like to surround themselves with unique items.







Letto Leonardo in rovere Wengè vissuto abbinato al gruppo letto Ray in laccato lucido. Nei dettagli il comodino Ray in laccato Deserto lucido; il dettaglio del piedino con finitura a 45°; e la speciale finitura dello scrittoio Ray in oleo-malta "Gres" Deserto.

Leonardo bed in aged Wengè oak matching Ray collection in high gloss White. Ray nightstand in high gloss Deserto; foot detail, cut at 45 degrees, and deserto "Gres" oleo-malta special finishing of Ray desk.







Gruppo letto Leonardo in rovere Visone vissuto.
Nei dettagli si apprezzano le lavorazioni a 45° e
le particolari inclinazioni del piede e della testata
del letto.

*Visone aged oak Leonardo collection. In details
special 45 degree cuts and special foot and
headboard bends.*

TUBE

TUBE

Forme morbide e materiali pregiati per un letto elegante e raffinato. Il massello tornito esprime il massimo valore dell'artigianalità delle lavorazioni aziendali.

Soft shapes and precious materials for an elegant and refined bed collection. The rounded massive wood structure expresses the maximum strength of the artisanal craftsmanship of the company.







Letto Tube in rovere Visone vissuto, abbinato al gruppo letto Brera in rovere Visone vissuto e top in pelle Extra Juta. Nei dettagli la lavorazione del letto in legno massello tornito e il gruppo letto Brera con top in pelle e maniglia a gola laterale.

Visone aged oak Tube bed, matching Brera collection in Visone aged oak and Juta Extra leather top. Details of the rounded massive wood and Brera collection with leather top and lateral built-in handle.







Letto Tube-soft in rovere Carbon vissuto e testata imbottita in eco-pelle Nocciola, abbinata al gruppo Ginevra in rovere Carbon vissuto. Nei dettagli si apprezza l'effetto "vintage" dell'eco-pelle della testata del letto, ed i dettagli stondati del gruppo letto Ginevra.

Carbon aged oak Tube-soft and upholstered headboard in eco-leather Nocciola, matching Carbon aged oak Ginevra collection. Details show leather "vintage" effect of bed headboard, and rounded details of Ginevra collection.



ELITE

ELITE

Un progetto nato dall'esigenza di trasmettere i valori Olivieri in una camera da letto lussuosa, rendendola speciale ed unica.

A project born from the need to transmit the values Olivieri in a luxurious bedroom, making it special and unique.







Letto Elite in tessuto Laliqie Seta. Nei dettagli si apprezza la qualità del tessuto, delle cuciture e delle lavorazioni del letto.

Elite bed in Seta Laliqie fabric. Remarkable notes: the quality of fabric, of stitching and bed woodworking.







Letto Elite in pelle Vintage visone abbinato al gruppo letto Brera in rovere Carbon e top nella stessa finitura del letto e armadio Glass in specchio fumè. Nei dettagli la cucitura esterna della pelle con taglio "al vivo"; il top del comodino e l'elegante armadio Glass.

Visone vintage leather Elite bed combined with Brera collection in Carbon oak with same bed leather vintage top, and Glass wardrobe in Smoked mirror. Details of the leather "raw" cut, nightstand top and elegant Glass wardrobe.



SELF

SELF

Caratterizzato da volumi geometrici e linee asciutte, Self è una collezione notte facile da ambientare nelle case di oggi. Il letto, i comodini e i cassettoni, offrono la massima flessibilità compositiva, per la più ampia possibilità di personalizzazione dell'ambiente.

Made of geometrical volumes and tight shapes, Self is a night collection easy to adapt in today's houses. Bed, nightstands, chests offer the highest flexibility, for the widest personalization of any place.







Gruppo letto Self in rovere Wengè vissuto. Nel dettaglio a sinistra si apprezza l'inclinazione della testata in legno e il "gioco" di spessori dei dettagli del letto e gruppo letto. In alto a destra il bellissimo comò Self largo 180 cm a 2 cassettoni con maniglia gola. Mentre in basso a destra il nuovo meccanismo a contenitore disponibile su questo letto. Nella pagina successiva l'armadio battente GAP B1 in laccato Lino opaco.

Self bed in Wengé aged oak. On the left hand-side, the special bend of the headboard and the balance between different thicknesses of bed and bed collection. Top hand-side, the beautiful Self chest wide 180 centimeters with two big drawers with built-in handle. While on bottom right hand-side, the new container mechanism available for this bed. Next page, GAP B1 swing wardrobe in lacquered mat Lino.



COMA

COMPLEMENTI NOTTE

NIGHT COMPLEMENTS

Per noi i gruppi notte sono oggetti semplici, utili ed affascinanti. Attraverso un grande equilibrio di volumi, poniamo particolare attenzione ad estetica, funzionalità e materiali.

For us, night collections are simple, useful and fascinating objects. Through a large balance of volumes, we spend particular attention to aesthetics and above functionality.



ANDREA

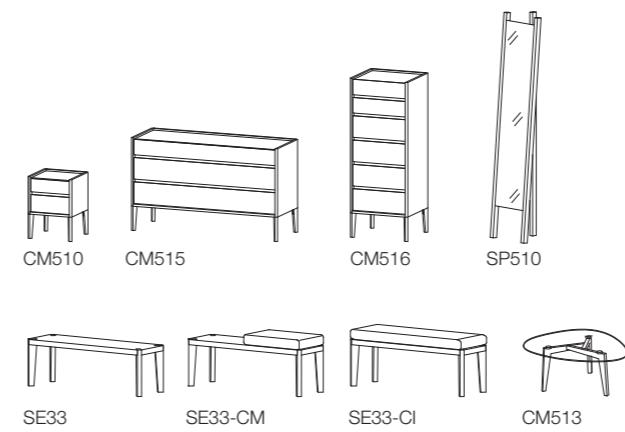

Cod.	Dim. (cm)	Cod.	Dim. (cm)
CM510	L 42 P 40,6 H 55,8	SE33	L 132 P 42 H 40/45
CM515	L 140 P 50 H 83,8	SE33-CM	L 132 P 42 H 40/45 (+10)
CM516	L 55 P 50 H 143,8	SE33-CI	L 132 P 42 H 40/45 (+10)
SP510	L 32,9 P 33,8 H 174,3	CM513	L 90 P 78 H 46,8



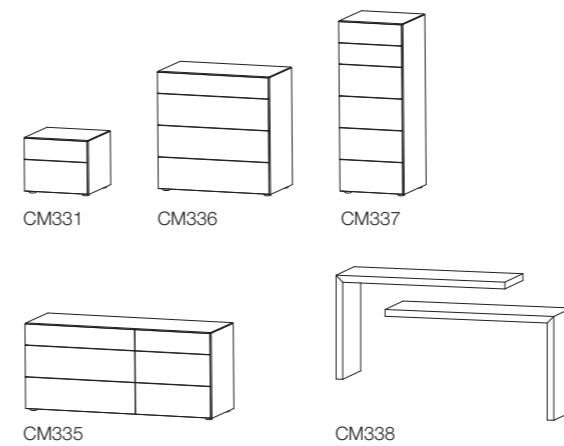

Cod.	Dim. (cm)	Cod.	Dim. (cm)
CM331	L 51,4 P 50 H 43	CM335	L 149,6 P 50 H 67,3
CM336	L 90 P 50 H 91,6	CM338	L 128 P 46 H 76,3
CM337	L 51,4 P 50 H 132,2		

BRERA

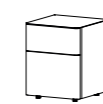

CM490

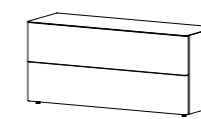

CM495

Cod.	Dim. (cm)
CM490	L 40,2 P 40,5 H 51,5
CM495	L 147,4 P 50,5 H 69,5

GINEVRA

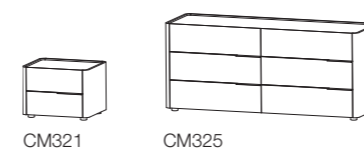

Cod.	Dim. (cm)
CM321	L 55 P 45 H 40,2
CM325	L 160 P 50 H 69,4

MARTIN

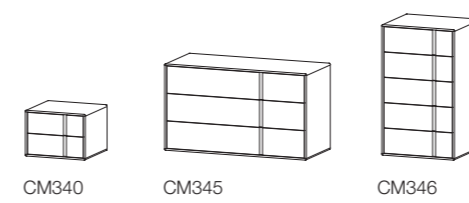

Cod.	Dim. (cm)
CM340	L 50 P 45,5 H 42,8
CM345	L 118,6 P 50 H 80,1
CM346	L 60,8 P 50 H 120,7

LEONARDO



Cod.	Dim. (cm)
CM501	L 53,6 P 46,5 H 42,2
CM500	L 37 P 39 H 53,5
CM505	L 122,2 P 50 H 74,5

SELF

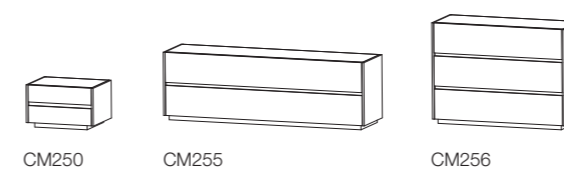

Cod.	Dim. (cm)
CM250	L 55 P 44,9 H 38,5
CM255	L 180 P 54 H 58,8
CM256	L 118,6 P 54 H 87,3

SOFTLY



Cod.	Dim. (cm)
SE30	L 58 P 68 H 81
SE31	L 64 P 64 H 81
SE32	L 70 P 70 H 35

VANITY

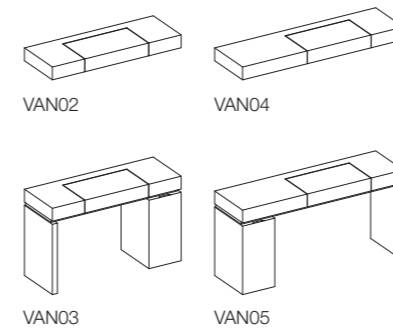

Cod.	Dim. (cm)
VAN02	L 128 P 46 H 12
VAN04	L 160 P 46 H 12
VAN03	L 128 P 46 H 80,7
VAN05	L 160 P 46 H 80,7

RINGRAZIAMENTI - *THANKS TO:*

INKIOSTRO BIANCO - WALLPAPER
MRS.ME - COPRILETTI / BEDDING
RENZO SERAFINI - ILLUMINAZIONE
MEME DESIGN - COMPLEMENTI DI ARREDO
VISTOSI - LAMPADE
NEVERHADBEFORE.IT - ILLUMINAZIONE
BALDININI - ABBIGLIAMENTO
FORME - COMPLEMENTI
MARTINELLI - LUCE
PENTA LIGHT - LUCE
AMINI CARPETS - TAPPETI
ALEX - CAPPELLI
PENTAGONO SETA - CRAVATTE
FRAG - SEDIE
GALLI - SCATOLE
DE VECCHI - ARGENTI
BALEANI RICCIONE - ALTA GIOIELLERIA
MATTIA FILIPUCCI & FILIPUCCI ARREDAMENTI
RIMINI HACKET RIMINI - ABBIGLIAMENTO
ILARIA FRANZA - PITTRICE
ILARIA MARELLI - DESIGNER ANDREA & KAL
MATERIUM.IT - OROLOGI A MURO

Progetto
Michele Sartini

Art Direction
Officine Bonfiglioli

Stylist
Morena Colombo

Fotografia
Riccardo Bianchi

Graphic design
Officine Bonfiglioli

Rendering e post-produzione
Officine Bonfiglioli

Fotolito
LifelnPixel

Stampa
La Pieve Poligrafica

